RAPTOR + BACKER HARDWARE DIAGRAM



Retention Adjustment

Light Compatible Retention Adjustment



Non-Light Retention Adjustment

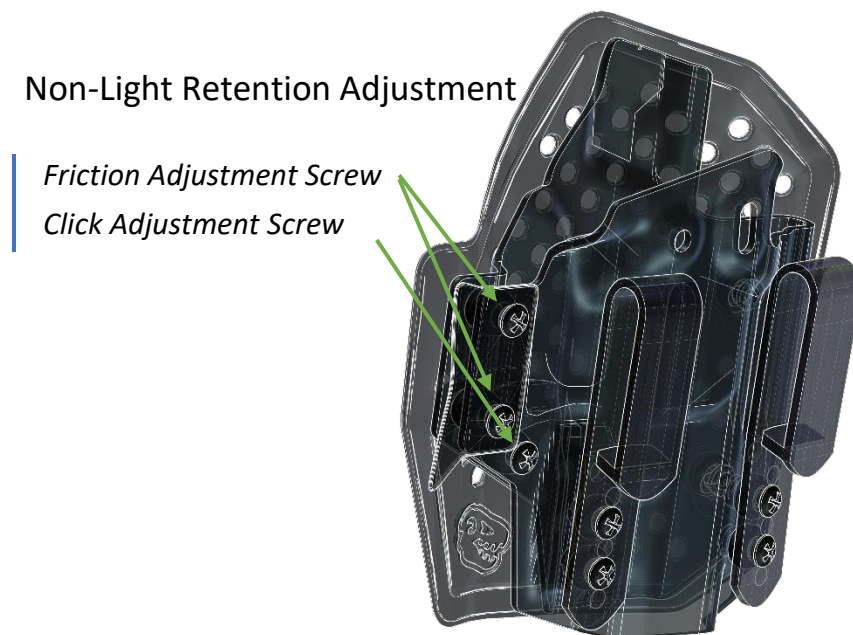

Hardware

Claw Installation (Install in sequence, back to front)

2 x .500" Post with Backer (.375 with Holster only)

2 x .125" Washers. Only use with Backer (Install between holster and Backer)

2 x .375" Washers (Inside holster)

1 x Claw

2 x .500" Screws



Unique Non-light Retention Screw (Install in sequence, back to front)

1 x .250" Post

1 x 3/75" Washer (inside holster)

1 x 3/75" Screw



Plastic/Metal Tuckable Clips Installation (*Install in sequence, back to front*)

2 x 250" Posts (Inside holster)

2 x 188" Washers (Between holster and clip)

1 x Plastic/Metal Tuckable Clip

2 x Screws Through clip (.375" Screws for Plastic or .250" Screws for Metal)

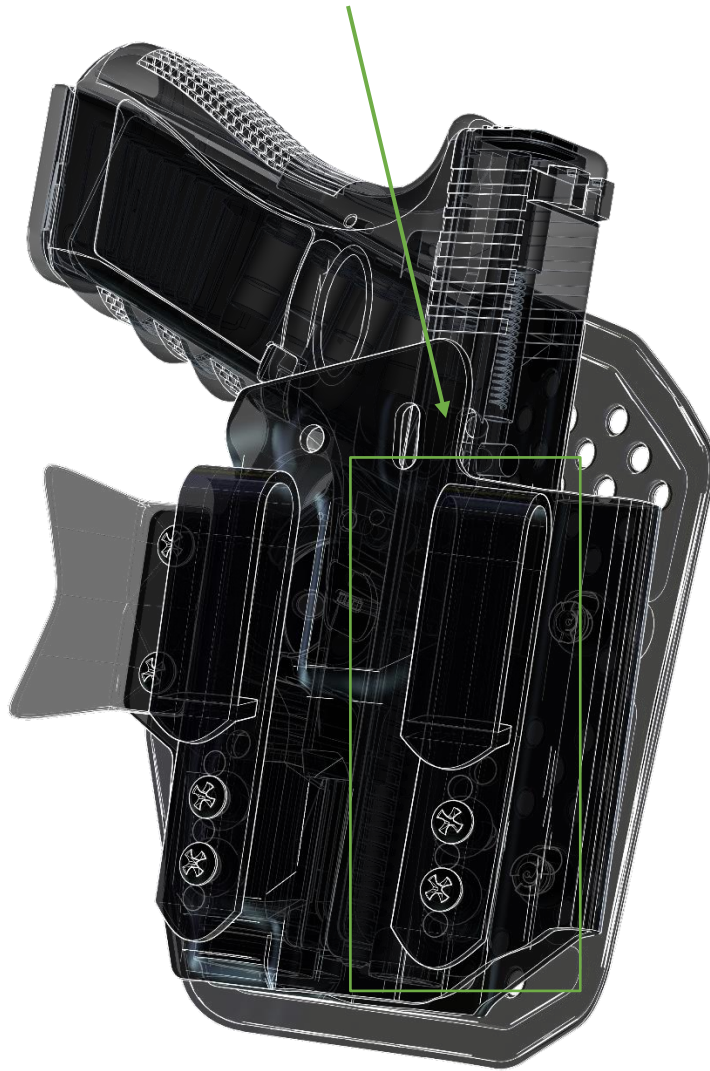

Raptor Backer

Claw side (Install claw side first)

Replace the .375" Posts with the .500" Posts (Reference the Claw Installation)



Sight channel side (The requisite Backer holes used will vary by holster model)

Use Backer holes that align with slots on holster. (Install claw side first)

2 x 250" Posts (Inside the sight channel on the holster)

2 x 188" Washers (Between holster and Backer)

2 x .250" Screws

Monoblock Installation (Sold separately)

Remove Tuckable Clips (Install in sequence, back to front)

2 x .250" Posts (Inside holster)

2 x .188" Washers (Between holster and Monoblock)

1 x Monoblock

2 x .250" Screws (Through Monoblock)

